

# CEFIC

Conseil Européen des  
Fédérations de l'Industrie Chimique

European Council of Chemical  
Manufacturers' Federations

## TEST METHODS FOR ACTIVATED CARBON

APRIL '86



TEST METHODS  
for  
ACTIVATED CARBON

# CONTENTS

|  |    |
|--|----|
| Foreword . . . . .   | 5  |
| Definition . . . . .   | 7  |
| 1. PHYSICAL TESTS . . . . .                                      | 9  |
| 1.1. Bulk Density . . . . .                                      | 9  |
| 1.2. Absolute Density . . . . .                                  | 11 |
| 1.3. Particle Density . . . . .                                  | 12 |
| 1.4. Particle Size . . . . .                                     | 14 |
| 1.5. Pressure Drop . . . . .                                     | 15 |
| 1.6. Mechanical Strength . . . . .                               | 18 |
| 2. ADSORPTION TESTS . . . . .                                    | 19 |
| 2.1. General Method for Measuring Isotherms . . . . .            | 19 |
| 2.2. Phenol Adsorption Isotherm . . . . .                        | 21 |
| 2.3. Iodine Adsorption . . . . .                                 | 23 |
| 2.4. Methylene Blue Value . . . . .                              | 25 |
| 2.5. Phenazone Adsorption . . . . .                              | 28 |
| 3. CHEMICAL and PHYSICO-CHEMICAL TESTS . . . . .                 | 30 |
| 3.1. Volatile Matter Content . . . . .                           | 30 |
| 3.2. Moisture Content . . . . .                                  | 32 |
| 3.3. Ash Content . . . . .                                       | 34 |
| 3.4. Ignition Temperature of Granular Activated Carbon . . . . . | 35 |
| 3.5. Self-Ignition Test acc. to IMDG-Code . . . . .              | 38 |
| 3.6. pH Value . . . . .  | 39 |
| 3.7. Water Soluble Content . . . . .                             | 40 |
| 3.8. Acid Soluble Content . . . . .                              | 42 |
| 3.9. Test for Polycyclic Aromatic Hydrocarbons (PAH) . . . . .   | 44 |
| 3.10. Heavy Metals Content . . . . .                             | 45 |
| Nomenclature . . . . .   | 47 |

## FOREWORD

In view of changing legislation within Europe in relation to the application, transport, storage, safety and handling of activated carbons in general, this brochure gives test methods for the evaluation of activated carbons.

These test methods have been studied by members of the Sector Group Activated Carbons, acting in the context of the European Council of Chemical Manufacturers' Federations (CEFIC).

This brochure is not intended to be a complete manual on the testing of activated carbons, although enough experimental details are given for those concerned.

For some tests, very specialized laboratory equipment is required, and in these cases only a general description has been given. Most of the tests described stem from sources such as ASTM, AWWA, DIN and ISO (\*).

The described test methods and the related data are provided on a purely informative basis.

Each potential user should judge these methods on their own merits and after careful consideration.

Therefore, the members of the Activated Carbons S.G., at the date of publication of their booklet, cannot accept any responsibility for the use of the relevant material but stress the fact that it has been compiled in good faith and with the latest knowledge in their possession.

For further information refer to the suppliers of activated carbon and to the hereunder mentioned reputed organizations to which we express our thanks for their contribution to the kind authorization they gave us to reproduce test methods.

(\*) The complete text of each method can be obtained from the various secretariats:  
ASTM: 1916 Race Street, Philadelphia PA 19103, USA  
AWWA: 6666 West Quincy Avenue, Denver Colorado 80235, USA  
DIN: Burggrafenstrasse 4-10, D-1000 Berlin 30, F.R. Germany  
ISO: Case Postale 56, CH-1211 Geneva 20, Switzerland, or any ISO member.

## DEFINITION

Activated carbons are non-hazardous, processed, carbonaceous products, having a porous structure and a large internal surface area. These materials can adsorb a wide variety of substances, i.e. they are able to attract molecules to their internal surface, and are therefore called adsorbents.

The volume of pores of the activated carbons is generally greater than  $0.2 \text{ ml.g}^{-1}$ . The internal surface area is generally greater than  $400 \text{ m}^2.\text{g}^{-1}$ . The width of the pores ranges from 0.3 to several thousand nanometers.

Note:

In this publication, granular activated carbons are defined as those having 90% of particles larger than 0.18 mm, as determined by test 1.4.

# 1. PHYSICAL TESTS

## 1.1. BULK DENSITY

### 1.1.1. Scope

The bulk density is defined as the mass of a unit volume of the sample in air, including both the pore system and the voids between the particles. It is expressed as  $\text{kg.m}^{-3}$  on dry basis.

The bulk density of activated carbon depends on the shape, size and density of the individual particles. Bulk density data are useful for the estimation of tank or packing volume.

### 1.1.2. Principle

There are two different standard methods for the preparation of a unit volume of powdered or granular activated carbon. The methods given below are adaptations of DIN ISO 787,11 and ASTM D 2854 respectively.

### 1.1.3. Apparatus and materials

Balance.

Desiccator.

Powdered activated carbons:

Stampfvolumeter, to DIN ISO 787,11.

Granular activated carbons:

Reservoir funnel,

Vibratory feed,

Feeding funnel (stem i.d. 24 mm) and 100 ml measuring cylinder, to ASTM D 2854.

### 1.1.4. Sample

The activated carbon sample may be tested dried, or as received. The bulk density is expressed as that of dry material.

The moisture content can be determined separately (see 3.2.) and the result corrected by calculation (see 1.1.6. Result).

### 1.1.5. Procedure

#### 1.1.5.1. Powdered Activated Carbon

The test is carried out in a graduated cylinder, fixed in a vertical tapping device, frequency  $250 \pm 15$  taps/min., amplitude 3 mm.

Place approximately 200 ml of activated carbon in the cylinder, avoiding entraining air.

Flatten the top layer by tapping the side of the cylinder. Fix the cylinder onto the machine and cycle 1250 times. Read the volume (V) and repeat the procedure until the difference between two observations is less than 2 ml. Weigh the contents of the cylinder to the nearest 0.1 g.

#### 1.1.5.2. Granular Activated Carbon

Carefully put a representative sample of the activated carbon into the reservoir funnel so that the material does not prematurely flow into the graduated cylinder. If this occurs, return the material to the reservoir funnel.

Transfer the sample from the reservoir funnel to the cylinder via the vibratory feeder and feeding funnel.

Fill the cylinder at a uniform rate not less than 0.75 or exceeding 1.0 ml.s<sup>-1</sup>, up to the 100ml mark. The rate can be adjusted by changing the slope of the metal vibrator or raising or lowering the reservoir funnel, or both.

Transfer the contents of the cylinder to a balance pan and weigh to the nearest 0.1 g.

#### 1.1.6. Result

The bulk density  $D_b$  is given in kg.m<sup>-3</sup> by:

$$D_b = 1000 \frac{M}{V}$$

where

M = mass of the sample in g

V = volume of the sample, measured under test conditions in ml.

If appropriate, correct for moisture content as follows:

$$D_b = 1000 \frac{M}{V} \frac{(100 - M_c)}{100}$$

$M_c$  = moisture content in % according to 3.2.

#### References:

DIN ISO 787,11 General methods of test for pigments and extenders; part 11; Determination of tamped volume and apparent density after tamping.  
The full text can be obtained from the ISO Central Secretariat, Case Postale 56, CH-1211 Geneva 20 or from any ISO member.

ASTM D 2854-70 Standard test method for apparent density of activated carbon.  
Extracts were reprinted, with permission, from the ANNUAL BOOK OF ASTM STANDARDS. Copyright ©, ASTM, 1916 Race Street, Philadelphia, PA. 19103.

## 1.2. ABSOLUTE DENSITY

### 1.2.1. Scope

The absolute or helium density is defined as the mass of a unit volume of the solid carbon skeleton, inaccessible to He, normally expressed as g.ml<sup>-1</sup>.

### 1.2.2. Principle

The volume of the skeleton of a carbon sample with known mass is measured by gas displacement.

### 1.2.3. Apparatus and materials

Commercial Helium pycnometer.

High vacuum system.

Desiccator with an efficient drying agent.

Helium.

### 1.2.4. Sample

The activated carbon sample is dried at 150 °C to constant weight.

### 1.2.5. Procedure

The test is carried out according to the directions given by the manufacturer of the instrument.

### 1.2.6. Result

The absolute density  $D_a$  in g.ml<sup>-1</sup> is given by:

$$D_a = \frac{M}{V}$$

where

M = mass of activated carbon in g

V = volume of skeleton in ml.

### 1.2.7. Note

Commercial He pycnometers are often operated by a microprocessor. The mass of the sample is entered and the value of the absolute density may be read directly.



### 1.3. PARTICLE DENSITY

#### 1.3.1. Scope

The particle density, otherwise known as Hg-density, is defined as the mass of a unit volume of the carbon particle, including its pore system, normally expressed as  $\text{g.ml}^{-1}$ .

The particle density is an important characteristic of granular carbon, being used for the determination of bed porosity or void fraction. This in turn, is necessary for the determination of numerous other properties.

Under the conditions of this method, pores  $\geq 7 \mu\text{m}$  radius are filled and therefore do not contribute to the density of the particle.

#### 1.3.2. Principle

The determination is based on simple pycnometry of solid bodies, with mercury acting as the medium. The mercury is added under vacuum in a specially designed pycnometer.

The temperature is controlled by a thermostat.

#### 1.3.3. Apparatus and materials

Pycnometer.

Filling device, as delivered with mercury porosimeters.

Double stage vacuum pump.

Manometer, Brunner type, (0.5 Pa).

Fume cupboard, designed for operation with mercury.

Thermostat, adjusted to  $20.0 \pm 0.10^\circ\text{C}$ .

Top loading balance, 300 g capacity, readable in 1 mg.

Syringe, 5 ml, preferably polythene.

Mercury, chemically pure.

High vacuum grease.

#### 1.3.4. Sample

As granular carbon samples fractionate easily and because only a minute quantity is taken for analysis, taking a representative part of the sample is vital.

The sample must be dry and/or fully desorbed.

#### 1.3.5. Procedure

##### 1.3.5.1. Calibration

Calibrate the pycnometer with mercury using the method outlined below, without the sample.

Repeat the calibration until two consecutive determinations show less than 50 mg difference.

Record the average mass of the pycnometer filled with mercury.

#### 1.3.5.2. Measurement

Take a dry and clean pycnometer with a stand, fill it to three quarters of its volume with sample and weigh.

Calculate the mass of the sample. Grease the joints slightly and close the pycnometer.

Position it in the filling device, evacuate to about 1 Pa and fill with mercury up to the mark.

If the granules are smaller than 1 mm, filling with mercury should be aided by admitting it slowly and tapping the stand with a light wooden hammer. If the mercury level falls sharply on breaking the vacuum, this is an indication of poor filling of the voids. In that case, repeat the determination.

Place the pycnometer in the thermostat and allow temperature equilibrium to be attained. Adjust the mercury level in the pycnometer with the syringe, if necessary. Dry the pycnometer carefully and weigh to 1 mg.

#### 1.3.6. Result

The particle density  $D_{\text{Hg}}$  is given in  $\text{g.ml}^{-1}$  by:

$$D_{\text{Hg}} = \frac{\rho_{\text{Hg}} M}{B + M - F}$$

where

- $\rho_{\text{Hg}}$  = density of mercury at 20 °C = 13.546  $\text{g.ml}^{-1}$
- B = mass of pycnometer filled with mercury in g.
- F = mass of pycnometer with mercury and carbon in g.
- M = mass of activated carbon in g.

#### 1.3.7. Notes

If the vacuum cannot be obtained within 30 minutes, there may be 3 causes:

- The carbon contains water or other volatiles.
- The system is leaking.
- The pump capacity is insufficient.

Caution; mercury vapours are toxic; consult safety instructions first.

#### 1.4. PARTICLE SIZE OF GRANULAR CARBON

##### 1.4.1. Scope

Grain size is an important property influencing the flow characteristics, adsorption kinetics and catalytic behaviour of granular activated carbon layers.

##### 1.4.2. Principle

All common methods provide mechanical separation with standard sieves, of which the aperture should be expressed in mm.

Determination of particle size by sieving is not applicable to extruded activated carbons.

##### 1.4.3. Apparatus and materials

Standard sieves  
Sieving machine  
Balance

##### 1.4.4. Sample

50 g (or 100 ml) of dried or undried activated carbon.

##### 1.4.5. Procedure

Many sieving methods, differing only in duration and technique of sieving (mechanical or manual), are used.

Collect and weigh the sieve fractions.

##### 1.4.6. Result

List wt.% of the sieve fractions in tabular form.

##### 1.4.7. Note

Graphical illustration of the result is generally convenient.

#### References:

ISO/R 566; 1967

ICUMSA, Report of the Proceedings 13th, session 1962, Subj. 5, Rec. I, 20.

ASTM D 2862 Standard test method for particle size distribution of granular activated carbon.

DIN 4188 Drahtsiebboeden fuer Analysensiebe.

## 1.5 PRESSURE DROP OF A GAS FLOW OVER A PACKED BED OF GRANULAR ACTIVATED CARBON

### 1.5.1. Scope

The pressure drop gives information about the resistance to flow of a gas through a carbon layer. The pressure drop over a packed bed is adequately defined by a modified form of the semi-empirical Ergun equation as a function of the form and size of the particles and the temperature, pressure and superficial velocity of the gas.

It is given in  $\text{Pa}\cdot\text{m}^{-1}$  of carbon bed length.

### 1.5.2. Principle

Air is passed through an activated carbon layer of given length. The pressure drop is measured as a function of gas velocity.

### 1.5.3. Apparatus

#### 1.5.3.1. Description (see drawing).

The apparatus consists of a vertical cylinder of transparent material, in which a downflow of air of known velocity can be created. At two fixed points, separated by 500 mm, connections are provided to a U-tube, partly filled with water, to measure  $\Delta P$  over this part of the column.

The velocity is measured with a flowmeter DOWNSTREAM of the column, to avoid deviations due to variable back pressure. A feeding device above the cylinder is used to build up an homogeneous carbon layer.

A measuring tape is attached to the mounting board to determine the height of the water level in the U-tube.

A ball valve is used to empty the cylinder conveniently.

#### 1.5.3.2. Specifications

Supply of compressed air, free of oil and water vapour, minimal working pressure 3 bar, up to  $8 \text{ m}^3\cdot\text{h}^{-1}$ .

Pressure regulator, preferably two stage.

Flowmeter, capacity  $8 \text{ m}^3\cdot\text{h}^{-1}$ .

Feeding device, vibratory type.

Funnel, so designed that the axis of the delivery tube coincides with the axis of the cylinder.

### 1.5.4. Sample

At least 2.0 litres of homogeneous, air dried sample should be used.

### 1.5.5. Procedure

#### 1.5.5.1. Calibration

The assembly is calibrated without carbon in the cylinder.

A gas meter (bellows type) is placed in between the cylinder and flowmeter

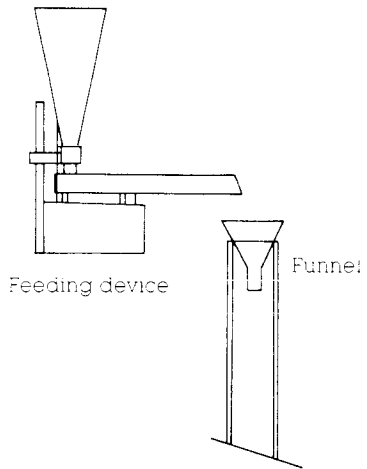

**DEVICE FOR PRESSURE DROP**

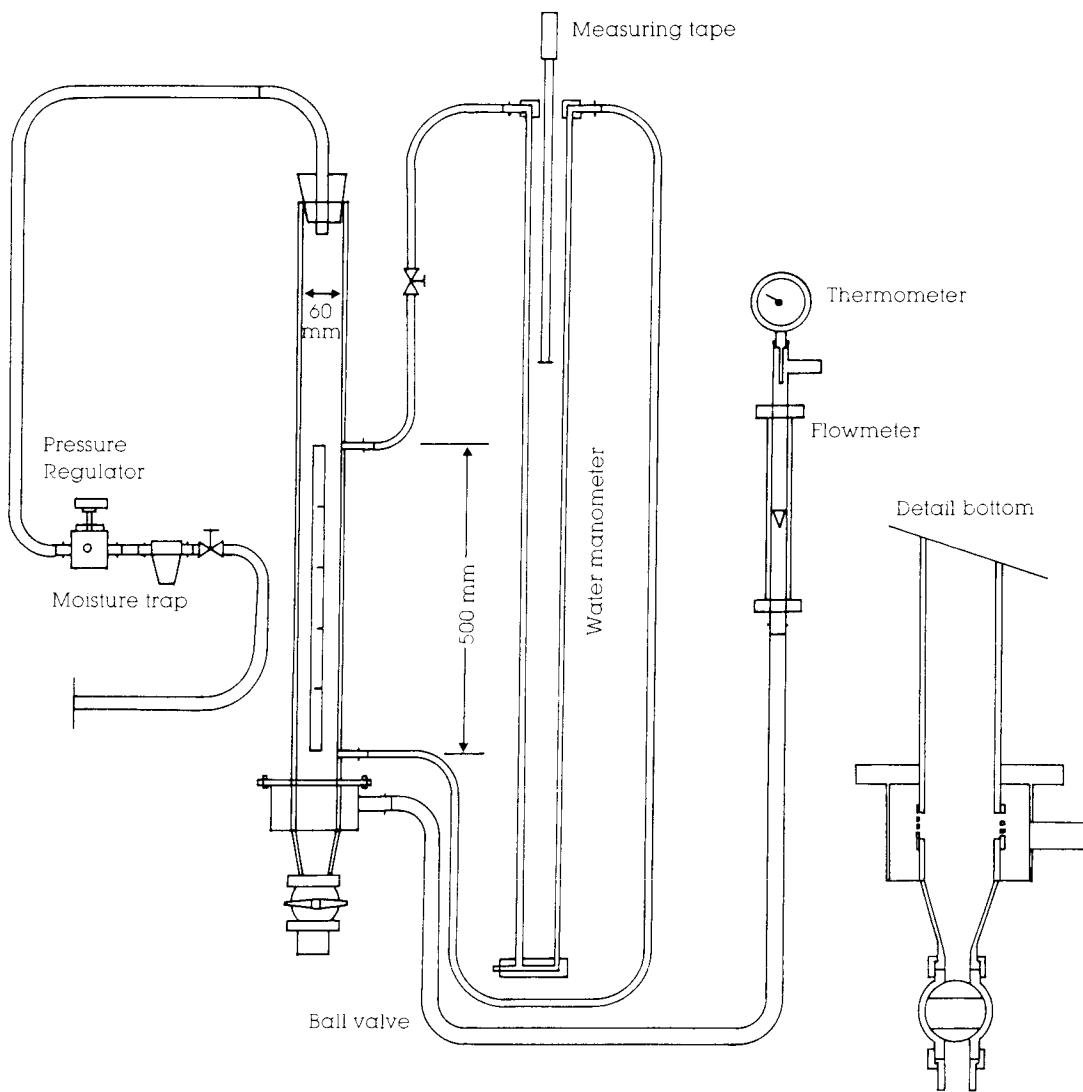

and connected by a full diameter flexible tube. The air flow is set at six or more points, evenly spaced over the entire range of the flowmeter scale.

At each point the volume of air is measured for at least 15 minutes. The calibration is carried out as close to 20 °C as practicable.

The superficial linear gas velocity is calculated for each point and the resulting table is used in the observations.

#### 1.5.5.2. Preparation

Make sure that the cylinder is exactly vertical. Correct if necessary. Position the vibratory feeder so that the discharge is just above the centre of the conical part of the cylinder funnel. Start feeding. Adjust the filling speed to 5 cm every 60 — 70 seconds. Keep checking. Make sure that the bed is building up horizontally. Stop feeding when the cylinder has been filled to a point above the upper measuring connection.

#### 1.5.5.3. Measurement

Remove the funnel and fit the stopper with the air supply in place, without disturbing the column.

Open the pressure valve and adjust the flow to the first tabulated values. Read the differential pressure.

Repeat for the remaining tabulated velocities.

Record temperature and barometric pressure.

#### 1.5.6. Result

Express by means of the modified ERGUN equation:

$$\frac{\Delta P}{L} = K_1 \mu_T V_o + K_2 \rho_{TP} V_o^2$$

where

- $\Delta P$  = pressure drop (Pa)
- $L$  = carbon column length (m)
- $V_o$  = superficial velocity of air ( $\text{m.s}^{-1}$ )
- $\mu_T$  = dynamic gas viscosity, depending on T (Pa.s)
- $\rho_{TP}$  = gas density, depending on T and P ( $\text{kg.m}^{-3}$ )
- $T$  = gas temperature (°K)
- $P$  = gas pressure (Pa)  $\approx P_B + \frac{1}{2} \Delta P$
- $P_B$  = barometric pressure (Pa)

$L$ ,  $V_o$  are given,  $\mu_T$  and  $\rho_{TP}$  can be extracted from tables and  $K_1$ ,  $K_2$  are constants determined by measuring  $\Delta P$  at six different air velocities  $V_o$  and calculated by the least squares method.

#### References:

- Brauer et al., Chem. Ing. Techn. 44 (1972) 93
- Ergun, Chem. Eng. Prog. 48, 2 (1952) 89.

## 1.6. MECHANICAL STRENGTH OF GRANULAR ACTIVATED CARBON

### 1.6.1. Scope

Mechanical strength is an important factor for most technical applications of granular activated carbon.

### 1.6.2. Principle

The determination of mechanical strength simulates the resistance to abrasion or attrition under practical conditions.

Depending on various practical requirements, there are many different test methods using vibration, impact and rotary motion or motion as in a fluidized bed. A variety of tests are available for the evaluation of the mechanical strength of granular activated carbon. In these tests the change in particle size distribution or the amount of fines produced is determined.

These tests all measure different aspects of the mechanical strength and thus cannot be related to one another mathematically.

Common used tests are:

— Ball-mill hardness.

The activated carbon is abraded for a given time in a horizontal cylinder with steel or ceramic balls under prescribed conditions.

— Abrasion strength.

The activated carbon is abraded by an iron rod in a horizontal rotating cylindrical sieve of given dimensions for a prescribed time.

— Impact hardness.

The activated carbon particles are broken by dropping a weight onto a sample under controlled conditions.

— Ball-pan hardness.

The activated carbon is shaken for a given time in a pan together with a given number of steel balls of known diameter.

— T-bar hardness.

The activated carbon is abraded in a cylindrical container with a T-shaped stirrer with a prescribed rotation speed and time.

— Crushing strength.

The pressure applied to crush a granule of activated carbon (not applicable for broken granules). Use commercially available apparatus.

— Impact-hardness (Fluidized bed).

The activated carbon is pneumatically agitated for a standard time in a vertical cylinder, the top of which is provided with an impact plate.

#### References:

AWWA standard for granular activated carbon: B 604 — 74

sect. 4.6 Abrasion resistance

4.6.2 Stirring abrasion test

4.6.3 Ro-Tap abrasion test

ICUMSA (1979) Sugar analysis Schneider F. p. 221

Attrition hardness.

ASTM D 3802 Standard test method for ball-pan hardness of activated carbon.

## 2. ADSORPTION TESTS

### 2.1. GENERAL METHOD FOR MEASURING ISOTHERMS (LIQUID PHASE)

#### 2.1.1. Scope

This method is a general procedure for the evaluation of an activated carbon by the adsorption isotherm technique. It provides a common basis for developing evaluation procedures for activated carbon in liquid phase applications.

#### 2.1.2. Principle

A sample of activated carbon is contacted for some time with a test solution containing a test substance (e.g. an impurity). A contact time sufficient for equilibrium or an other well defined reference state to be reached, is chosen. An isotherm, relating to the corresponding concentrations of the test substance in the liquid (residual concentration) and the solid (load) phase, is then plotted.

An extended test, called the Adsorbate Relative Efficiency Test, has as its objective the determination of the relative adsorptive capacities of the test and reference activated carbons.

#### 2.1.3. Apparatus and materials

The apparatus required for carrying out this procedure should be compatible with the requirements of each specific industry. The test solution shall be a standard solution appropriate to the application of the carbon, if and when a specific industry has established a standard test. Otherwise, the test solution shall be representative of the process stream. The composition of the test solution, together with its pH value and temperature should be standardized.

#### 2.1.4. Sample

Weigh the carbons on an «as is» basis to the nearest mg. Determine the moisture (see 3.2), the final results can then be expressed both on an «as is» basis and on a dry basis.

The procedure to be described applies to either powdered or granular activated carbon.

When granular carbon is to be tested by this procedure, a sufficiently long contact time should be allowed to enable the equilibrium or the reference state to be reached. Alternatively, the granular carbon may be pulverized (< 0.1 mm).

#### 2.1.5. Procedure

An appropriate aliquot quantity of the test solution shall be used to obtain at least a four point adsorption isotherm for each carbon.

Weigh the activated carbons into appropriate flasks containing the respective aliquots of test solution.



Place the carbon slurries and the blanks (if any) in a suitable agitator designed to keep the carbon in suspension at a prescribed time and temperature required to achieve the reference state. Both the contact time and temperature will be made the subjects of separate studies to optimize these conditions for a given application.

Filter out the activated carbon and determine the residual concentration of the solute in each filtrate and the blank by a suitable analytical procedure.

#### 2.1.6. Result

Calculations and interpretation of data. Use the empirical Freundlich equation for the adsorption isotherm as follows:

$$\frac{X}{M} = K C_f^{1/n}$$

where

$\frac{X}{M}$  = matter removed per unit mass of carbon, dry or «as is» basis

X = amount of matter removed

M = mass of carbon used

$C_o$  = initial concentration before carbon treatment

$C_f$  = final concentration after carbon treatment

K and  $1/n$  are constants for a given adsorption system.

If the Freundlich equation is expressed logarithmically,

$$\log \frac{X}{M} = \log K + \frac{1}{n} \log C_f$$

then it has the form of a straight-line equation.

If the relative efficiency of a test carbon is required, contact weighed portions of this test carbon and of a known reference carbon with the same test solution.

The masses of a reference carbon must be fixed for each given test solution by predetermining what dosages are required to obtain an adsorption isotherm over the desired purification range.

Plot two isotherms and compare the efficiency of the carbons at the same residual concentration.

If the mass of a reference carbon is  $M_r$ , and the mass of test carbon is  $M_t$ , then the relative efficiency RE of the test carbon is as follows:

$$RE = 100 \frac{M_r}{M_t}$$

where:

RE = Relative Efficiency in %

Reference:

ASTM D 2355-70 Liquid Phase Evaluation of Activated Carbon

Extracts were reprinted with permission, from the Annual Book of ASTM Standards.

Copyright ©, ASTM, 1916 Race Street, Philadelphia, P.A. 19103.

## 2.2. PHENOL ADSORPTION ISOTHERM

### 2.2.1. Scope

The phenol adsorption isotherm gives an indication of the adsorptive properties of activated carbon, for example in water treatment.

### 2.2.2. Principle

The phenol adsorption capacity is measured by means of an adsorption isotherm, see 2.1.

### 2.2.3. Apparatus and materials

Spectrophotometer.

Shaking machine.

Phenol standard solution, 1000 mg.l<sup>-1</sup> (stable for 1 month).

Buffer solution pH 10.0.

Dissolve 20 g ammonium chloride in about 800 ml of water and adjust to pH 10.0 ± 0.2 with concentrated ammonia.

Make up to 1 l.

4-amino phenazone solution, 2% (w/v) in water.

Prepare freshly before use.

Potassium ferricyanide solution, 8% (w/v) in water.

This solution will keep one week, if stored in an amber bottle.

### 2.2.4. Sample

Granular activated carbon is pulverized (< 0.1 mm) and then dried at 150 °C to constant weight.

### 2.2.5. Procedure

Prepare a series of five carbon suspensions in water, for instance 100 — 200 — 300 — 400 — 500 mg per 990 ml, depending on the anticipated adsorption. Add 10.0 ml phenol solution (1000 mg.l<sup>-1</sup>), agitate for 3 hours at ambient temperature.

Filter through a folded filter paper, discarding the first 200 ml filtrate and using the next 100 ml for the test.

Add to 100.0 ml of filtrate respectively, 5.0 ml of buffer solution, 2.0 ml of 4-amino phenazone solution and 2.0 ml of potassium ferricyanide solution.

Read the absorbance after 15 minutes at 510 nm against a reagent blank. Obtain the phenol concentrations from a calibration graph, determined by treating phenol solutions of known concentrations in the same way.

For the determination of lower concentrations of phenol an extraction step with chloroform could be added.

#### 2.2.6. Result

The wt.% phenol load  $Q_p$  of the five carbon dose levels is given by:

$$Q_p = (C_o - C_f) \frac{V}{10 M}$$

where

- $Q_p$  = phenol load of the carbon (wt.%)
- $C_o$  = original phenol concentration in  $\text{mg.l}^{-1}$  (= 10)
- $C_f$  = residual phenol concentration in  $\text{mg.l}^{-1}$
- $V$  = volume of phenol solution in l (= 1)
- $M$  = mass of activated carbon in g

Plot the load  $Q_p$  versus the residual concentration  $C_f$  in the form of a Freundlich adsorption isotherm (see 2.1.6).

#### Reference:

ASTM D 1783-70 (Analysis) Phenolic Compounds in Water

Extracts were reprinted, with permission, from the Annual Book of ASTM Standards.

Copyright ©, ASTM, 1916 Race Street, Philadelphia, P.A. 19103.

DIN 19 603 Aktivkohle zur Wasseraufbereitung

Technische Lieferbedingungen.

Extracts were reproduced with permission of DIN Deutsches Institut für Normung e.V.

The edition of this standard with the latest date of issue, to be obtained from Beuth Verlag GmbH, Burggrafenstrasse 4-10, D-1000 Berlin 30, is the authoritative version for implementation of the standard.

## 2.3 IODINE ADSORPTION

### 2.3.1. Scope

The determination of the iodine number is a simple and quick test, giving an indication of the internal surface area of activated carbon.

### 2.3.2. Principle

The iodine number is defined as the number of milligrams of iodine adsorbed from an aqueous solution by 1 g of activated carbon when the iodine concentration of the residual filtrate is 0.02 N.

### 2.3.3. Apparatus and materials

Glass stoppered flasks, pipettes, burette.

Folded filters, Whatman 2V, 18 cm Ø.

Hot-plate.

Hydrochloric acid, 5 per cent (w/w).

Sodium thiosulphate solution, 0.10 N, standardized.

Iodine solution, 0.10 N, standardized.

Starch solution.

### 2.3.4. Sample

Granular activated carbon is pulverized ( $< 0.1$  mm) and then dried at 150 °C to constant weight.

### 2.3.5. Procedure

Depending on the activity of the carbon, weigh 0.700 — 2.000 g of the dried carbon and transfer the weighed sample to a dry, glass stoppered 250 ml Erlenmeyer flask.

Pipette 10 ml of 5% HCl into the flask and swirl until the activated carbon is wetted.

Place the flask on a hot-plate, bring the contents to the boil, and allow to boil for exactly 30 seconds.

Allow the flask and contents to cool to room temperature, then add by pipette 100 ml of 0.10 N iodine solution.

Stopper the flask immediately and shake it vigorously for 30 seconds. Filter by gravity through a filter paper immediately after the 30 seconds shaking period.

Discard the initial 20 — 30 ml of filtrate and collect the remainder in a clean beaker.

Stir the filtrate in the beaker with a glass rod and pipette 50 ml into a 250 ml Erlenmeyer flask.

Titrate the 50 ml sample with 0.10 N sodium thiosulphate solution until the yellow colour has almost disappeared. Add about 1 ml of starch solution and continue titration until the blue indicator colour just disappears. Record the volume of sodium thiosulphate solution used.

### 2.3.6. Result

Calculate the iodine number  $I_n$  of the carbon using the equation:

$$I_n = \frac{X}{M} A$$

where

X = mg of iodine adsorbed by the activated carbon

X =  $(12.693 N_1) - (279.246 N_2 V)$

herein

$N_1$  = normality of iodine solution

$N_2$  = normality of sodium thiosulphate solution

V = volume of sodium thiosulphate solution in ml

M = mass of activated carbon in g

A = correction factor, depending on the residual normality  $N_r$  of the filtrate

This factor A may be applied if  $N_r$  is between 0.008 and 0.0334 N.

$$N_r = N_2 \frac{V}{50}$$

A is given in the table below. A may vary from 1.1625 to 0.925. If  $N_r$  is outside the range of 0.008 to 0.0334 N, the determination has to be repeated either with a larger amount of activated carbon if  $N_r > 0.0334$  or a smaller amount if  $N_r < 0.008$ .

Reference:

AWWA B 600-78 Powdered Activated Carbon.

Extracts were reprinted, from B600-78- *AWWA Standard for Activated Carbon*, by permission.

Copyright © 1978, the American Water Works Association.

### CORRECTION FACTOR FOR IODINE ADSORPTION

| Residual<br>filtrate<br>Normality | 0.0000 | 0.0001 | 0.0002 | 0.0003 | 0.0004 | 0.0005 | 0.0006 | 0.0007 | 0.0008 | 0.0009 |
|-----------------------------------|--------|--------|--------|--------|--------|--------|--------|--------|--------|--------|
| 0.0080                            | 1.1625 | 1.1613 | 1.1600 | 1.1575 | 1.1550 | 1.1533 | 1.1513 | 1.1500 | 1.1475 | 1.1463 |
| 0.0090                            | 1.1438 | 1.1425 | 1.1400 | 1.1375 | 1.1363 | 1.1350 | 1.1325 | 1.1300 | 1.1288 | 1.1275 |
| 0.0100                            | 1.1250 | 1.1238 | 1.1225 | 1.1213 | 1.1200 | 1.1175 | 1.1163 | 1.1150 | 1.1138 | 1.1113 |
| 0.0110                            | 1.1100 | 1.1088 | 1.1075 | 1.1063 | 1.1038 | 1.1025 | 1.1000 | 1.0988 | 1.0975 | 1.0963 |
| 0.0120                            | 1.0950 | 1.0938 | 1.0925 | 1.0900 | 1.0888 | 1.0875 | 1.0863 | 1.0850 | 1.0838 | 1.0825 |
| 0.0130                            | 1.0800 | 1.0788 | 1.0775 | 1.0763 | 1.0750 | 1.0738 | 1.0725 | 1.0713 | 1.0700 | 1.0688 |
| 0.0140                            | 1.0675 | 1.0663 | 1.0650 | 1.0625 | 1.0613 | 1.0600 | 1.0583 | 1.0575 | 1.0563 | 1.0550 |
| 0.0150                            | 1.0538 | 1.0525 | 1.0513 | 1.0500 | 1.0488 | 1.0475 | 1.0463 | 1.0450 | 1.0438 | 1.0425 |
| 0.0160                            | 1.0413 | 1.0400 | 1.0388 | 1.0375 | 1.0375 | 1.0363 | 1.0350 | 1.0333 | 1.0325 | 1.0313 |
| 0.0170                            | 1.0300 | 1.0288 | 1.0275 | 1.0263 | 1.0250 | 1.0245 | 1.0238 | 1.0225 | 1.0208 | 1.0200 |
| 0.0180                            | 1.0200 | 1.0188 | 1.0175 | 1.0163 | 1.0150 | 1.0144 | 1.0138 | 1.0125 | 1.0125 | 1.0113 |
| 0.0190                            | 1.0100 | 1.0088 | 1.0075 | 1.0075 | 1.0063 | 1.0050 | 1.0050 | 1.0038 | 1.0025 | 1.0025 |
| 0.0200                            | 1.0013 | 1.0000 | 1.0000 | 0.9988 | 0.9975 | 0.9975 | 0.9963 | 0.9950 | 0.9950 | 0.9938 |
| 0.0210                            | 0.9938 | 0.9925 | 0.9925 | 0.9913 | 0.9900 | 0.9900 | 0.9888 | 0.9875 | 0.9875 | 0.9863 |
| 0.0220                            | 0.9863 | 0.9850 | 0.9850 | 0.9838 | 0.9825 | 0.9825 | 0.9813 | 0.9813 | 0.9800 | 0.9788 |
| 0.0230                            | 0.9788 | 0.9775 | 0.9775 | 0.9763 | 0.9763 | 0.9750 | 0.9750 | 0.9738 | 0.9738 | 0.9725 |
| 0.0240                            | 0.9725 | 0.9708 | 0.9700 | 0.9700 | 0.9688 | 0.9688 | 0.9675 | 0.9675 | 0.9663 | 0.9663 |
| 0.0250                            | 0.9650 | 0.9650 | 0.9638 | 0.9638 | 0.9625 | 0.9625 | 0.9613 | 0.9613 | 0.9606 | 0.9600 |
| 0.0260                            | 0.9600 | 0.9588 | 0.9588 | 0.9575 | 0.9575 | 0.9563 | 0.9563 | 0.9550 | 0.9550 | 0.9538 |
| 0.0270                            | 0.9538 | 0.9525 | 0.9525 | 0.9519 | 0.9513 | 0.9513 | 0.9506 | 0.9500 | 0.9500 | 0.9488 |
| 0.0280                            | 0.9488 | 0.9475 | 0.9475 | 0.9463 | 0.9463 | 0.9463 | 0.9450 | 0.9450 | 0.9438 | 0.9438 |
| 0.0290                            | 0.9425 | 0.9425 | 0.9425 | 0.9413 | 0.9413 | 0.9400 | 0.9400 | 0.9394 | 0.9388 | 0.9388 |
| 0.0300                            | 0.9375 | 0.9375 | 0.9375 | 0.9363 | 0.9363 | 0.9363 | 0.9363 | 0.9350 | 0.9350 | 0.9346 |
| 0.0310                            | 0.9333 | 0.9333 | 0.9325 | 0.9325 | 0.9325 | 0.9319 | 0.9313 | 0.9313 | 0.9300 | 0.9300 |
| 0.0320                            | 0.9300 | 0.9294 | 0.9288 | 0.9288 | 0.9280 | 0.9275 | 0.9275 | 0.9275 | 0.9270 | 0.9270 |
| 0.0330                            | 0.9263 | 0.9263 | 0.9257 | 0.9250 | 0.9250 |        |        |        |        |        |

Reprinted from B 600-78 — *AWWA Standard for activated carbon*, by permission.  
Copyright © 1978, the American Water Works Association.

## 2.4. METHYLENE BLUE VALUE

### 2.4.1. Scope

The methylene blue value gives an indication of the adsorption capacity of an activated carbon for molecules having similar dimensions to methylene blue. It is a quick method for comparing different batches of activated carbon of the same quality.

### 2.4.2. Principle

The methylene blue value is defined as the number of millilitres standard methylene blue solution decolourized by 0.1 g of activated carbon (dry basis).

### 2.4.3. Apparatus and materials

Glass stoppered flask.

Filters.

Methylene blue test solution:

Dissolve a quantity, equivalent to 1200 mg of pure dye (approx. 1.5 g Methyleneblau DAB VI or equivalent \*) to 1000 ml in a volumetric flask. Allow the solution to stand several hours or overnight.

Check the solution by diluting 5.0 ml with 0.25% (v/v) acetic acid to 1 l in a volumetric flask and measuring the absorbance at 620 nm for 1 cm. The absorbance must be  $0.840 \pm 0.01$ .

If the absorbance is higher, dilute with the calculated amount of water. If lower, discard the solution and start over.

### 2.4.4. Sample

Granular activated carbon is pulverized ( $< 0.1$  mm) and then dried at  $150^{\circ}\text{C}$  to constant weight.

### 2.4.5. Procedure

Contact exactly 0.1 g of the carbon sample with 25 (5)\*\* ml of the methylene blue test solution in a glass stoppered flask. Shake until decolourization occurs. Then add a further 5 (1)\*\* ml of the methylene blue test solution and shake to decolourization. Repeat the addition of methylene blue test solution in 5 (1) ml portions as long as decolourization occurs within five minutes.

Note the entire volume of test solution decolourized by the sample.

Repeat the test to confirm the result obtained.

### 2.4.6. Result

The volume of methylene blue test solution in ml that is just decolourized, is the methylene blue value of the activated carbon.

2.4.7. **Notes**

- \* Do not dry, methylene blue is heat sensitive. Correct for water content.
- \*\* Establish in preliminary testing whether to use an initial 25 ml methylene blue test solution with 5 ml additions, or 5 ml with 1 ml additions.

Reference:  
Deutsches Arzneibuch 6th Edition.



## 2.5. PHENAZONE ADSORPTION

### 2.5.1. Scope

Phenazone adsorption is a test to estimate the adsorption capacity of activated carbon for pharmaceutical purposes.

### 2.5.2. Principle

The phenazone adsorption is defined as the mass of phenazone (g) adsorbed from aqueous solution in 15 minutes per 100 g of activated carbon, referred to dry basis.

### 2.5.3. Apparatus and materials

Glass stoppered flask, pipettes, burette

Filtration equipment.

1% (w/w) aqueous solution of phenazone (freshly prepared).

Potassium bromide.

Dilute hydrochloric acid (2 N).

0.1 N potassium bromide/bromate solution.

Ethoxychrysoidine solution 0.1% (w/v) in 96% (w/v) ethanol.

### 2.5.4. Sample

Granular activated carbon is pulverized (< 0.1 mm) and may be dried (150 °C) before testing.

### 2.5.5. Procedure

Shake thoroughly about 0.30 g, accurately weighed activated carbon, for 15 minutes in a 100 ml ground glass stoppered Erlenmeyer flask with 25.0 ml 1% (w/w) phenazone solution.

Filter, rejecting the first 5 ml of filtrate.

To 10.0 ml of the solution add 0.5 g of potassium bromide and 20 ml of dilute hydrochloric acid.

Titrate with 0.1 N bromide/bromate solution, using 0.1 ml of ethoxychrysoidine solution as indicator, until the colour changes from raspberry red to pinkish yellow. Titrate slowly (1 drop every 15 seconds) towards the end of the titration.

Carry out a blank test on 10.0 ml of the phenazone solution.

### 2.5.6. Result

The percentage of phenazone  $Q_{Pz}$  adsorbed is given by:

$$Q_{Pz} = \frac{(B - F) 2.353}{M}$$

where

B = 0.1 N bromide/bromate used in the blank in ml

F = 0.1 N bromide/bromate used in the test in ml

M = mass of the activated carbon sample used, calculated with reference to the dried substance in g

Reference:

European Pharmacopoeia

(«Carbo Activatus», «Phenazonum»).

### 3. CHEMICAL AND PHYSICO-CHEMICAL TESTS

#### 3.1. VOLATILE MATTER CONTENT

##### 3.1.1. Scope

The International Standard for determination of volatile matter of hard coal and coke is also applicable to activated carbon.

##### 3.1.2. Principle

The sample is heated at 900 °C for 7 minutes.

The percentage of volatile matter is calculated from the loss in mass of the sample, corrected for moisture content.

##### 3.1.3. Apparatus and materials \*

Muffle furnace.

A furnace, heated by electricity, in which an adequate zone can be maintained at a constant and uniform temperature of  $900 \pm 10$  °C. It may be of the stop-ended type or fitted at the back with a flue, diameter of approximately 25 mm and a length of 150 mm.

Balance, accurate to 0.1 mg.

Other equipment (pyrometer, crucible, lid and stand).

Desiccator with an efficient drying agent such as anhydrous calcium chloride or equivalent.

##### 3.1.4. Sample

Granular activated carbon is pulverized ( $< 0.1$  mm)..

##### 3.1.5. Procedure \*

Adjust the temperature in the reaction zone of the muffle furnace, containing empty crucibles, to  $900 \pm 10$  °C.

Maintain steady temperature conditions in the furnace.

Weigh  $1.000 \pm 0.010$  g of the sample into each crucible, place the lids on the crucibles, transfer to the muffle furnace and leave for exactly 7 min at  $900 \pm 10$  °C.

Remove, allow to cool and weigh the crucibles.

##### 3.1.6. Result

The volatile matter content on dry basis,  $V_d$  in %, is given by:

$$V_d = 100 \frac{100 (B - F) - M_c (B - G)}{(B - G) (100 - M_c)}$$

where

B = mass in g of the crucible, lid and sample before heating

F = mass in g of the crucible, lid and contents after heating

G = mass in g of the empty crucible and lid

$M_c$  = moisture, as a percentage by mass, in the sample as analysed, determined according to the method specified in 3.2.

3.1.7. **Note**

\* It is necessary to consult the original ISO test to ensure correct results.

Reference:

ISO 562-1981 Determination of the volatile matter content of hard coal and coke.

The full text can be obtained from the ISO Central Secretariat, Case Postale 56,  
CH-1211: Geneva 20 or from any ISO member.

## 3.2. MOISTURE CONTENT

### 3.2.1. Scope

This method covers the determination of the moisture content of activated carbon. The oven drying method is used when water is the only volatile material present in the activated carbon. (A xylene distillation method is used when the carbon is known or suspected to be heat-sensitive or to contain water insoluble volatile compounds as well as water).

### 3.2.2. Principle

Heating the sample in air in an oven at constant temperature to constant weight.

### 3.2.3. Apparatus and materials

Oven, electrically heated, forced circulation drying oven, capable of temperature regulation between 145 and 155 °C.

Squat form glass weighing bottles with ground glass stoppers, or seamless metal crucibles with lids may be used. They should be as shallow as possible, consistent with convenient handling.

Desiccator, with an efficient drying agent such as anhydrous calcium chloride or equivalent.

### 3.2.4. Sample

Powdered Activated Carbon.

Take a 1 to 2 g representative sample, with a spoon or spatula from the sample bottle.

Granular Activated Carbon.

Take a 5 to 10 g representative sample.

### 3.2.5. Procedure

Put the sample into a pre-dried tared weighing bottle or crucible with lid, close and weigh at once to the nearest 0.5 mg. The depth of the carbon in the container must not exceed 1.25 cm.

Remove the lid and place the container and lid in a preheated forced circulation oven (at 150 °C). Close the oven and dry to constant weight (3h is normally sufficient).

Open the oven and close the container quickly. Cool in a desiccator to ambient temperature and weigh.

### 3.2.6. Result

The moisture content  $M_c$  in % is given by:

$$M_c = 100 \frac{B - F}{B - G}$$

where

- B = mass of container with lid plus original sample in g
- F = mass of container with lid plus dried sample in g
- G = mass of container with lid in g

Reference:

ASTM D 2867-70 Moisture in Activated Carbon.

Extracts were reprinted, with permission, from the *Annual book of ASTM Standards*. Copyright©, ASTM, 1916 Race Street, Philadelphia, PA. 19103.

### 3.3. ASH CONTENT

#### 3.3.1. Scope

This method covers the determination of the total ash content of activated carbon.

#### 3.3.2. Principle

Ignition of the sample to constant weight.

#### 3.3.3. Apparatus and materials

Muffle furnace, having air circulation, capable of temperature regulation to  $650 \pm 25$  °C.

High-temperature crucible.

Analytical balance, having a sensitivity of 0.1 mg.

Desiccator with an efficient drying agent.

#### 3.3.4. Sample

Dry an adequate sample of activated carbon to constant weight at 150 °C (3h is usually sufficient).

#### 3.3.5. Procedure

Ignite the crucible in the muffle furnace at  $650 \pm 25$  °C for 1 h. Place the crucible in the desiccator. Cool to room temperature and weigh to the nearest 0.1 mg.

Weigh out to the nearest 0.1 mg sufficient dried activated carbon, so that the estimated amount of ash will be 0.1 g, into the ignited crucible.

Place the crucible in the furnace at  $650 \pm 25$  °C. Ashing will take from 3 to 16 h, depending on the type of activated carbon and its particle size. Ashing can be considered complete when constant weight is achieved.

Place the crucible in the desiccator and allow to cool to room temperature. When cool, admit air slowly to avoid loss of ash from the crucible. Weigh to the nearest 0.1 mg.

#### 3.3.6. Result

The ash content  $A_c$  is given in % by:

$$A_c = 100 \frac{F - G}{B - G}$$

where

G = mass of empty crucible in g

B = mass of crucible plus dried sample in g

F = mass of crucible plus ashed sample in g

Reference:

ASTM D 2866-70 Total Ash Content of Activated Carbon.

Extracts were reprinted, with permission, from the *Annual book of ASTM Standards*. Copyright©, ASTM, 1916 Race Street, Philadelphia, PA. 19103.

### 3.4. IGNITION TEMPERATURE OF GRANULAR ACTIVATED CARBON

#### 3.4.1. Scope

This method covers the determination of the reference ignition temperature of granular activated carbon in an air flow. The test provides a basis for comparing the ignition characteristics of different carbons, or the change in ignition characteristics of the same carbon after a period of service.

#### 3.4.2. Principle

A sample of carbon is exposed to a heated air stream, the temperature of which is slowly increased until the carbon ignites. The temperature of the carbon bed and of the air entering the bed are recorded, and ignition is defined as the point at which the carbon temperature suddenly rises above the temperature of the air entering the bed.

#### 3.4.3. Apparatus

Quartz ignition tube and sample holder.

Thermocouples.

Supply of clean, dry, oil-free air.

Flowmeter, capable of metering air flow rates to  $20 \text{ l.min}^{-1}$ .

Heating mantle, tape, or oven to surround the ignition tube, at least 50 W capacity.

Supply of compressed nitrogen.

Quartz beads, 4 mm diameter or less to prevent fluidization.

Sieves, (two),  $150 \mu\text{m}$  aperture.

#### 3.4.4. Sample

Obtain a representative sample of carbon of approximately 35 ml. Place the sample between the two sieves and blow clean, dry, oil-free air through it to remove dust. The air flow velocity through the sieves shall be  $60 \pm 20 \text{ m.min}^{-1}$ .

#### 3.4.5. Procedure

Fill the ignition tube to a depth of  $25 \pm 1 \text{ mm}$ .

Cover the sample with quartz beads to a depth of at least 15 mm to prevent fluidization of the carbon bed.

Adjust the air flow rate to  $14.7 \pm 0.3 \text{ l.min}^{-1}$ , equivalent to a superficial velocity of  $30 \pm 0.5 \text{ m.min}^{-1}$ .

Increase the temperature of the air stream reaching the sample at a rate of approximately  $10 \text{ }^\circ\text{C.min}^{-1}$ .

Continue until the air temperature reaches approximately  $150 \text{ }^\circ\text{C}$  or is approximately  $50 \text{ }^\circ\text{C}$  below the anticipated ignition temperature of the sample. At this point reduce the air rate of heating to approximately 2 to  $3 \text{ }^\circ\text{C.min}^{-1}$ .



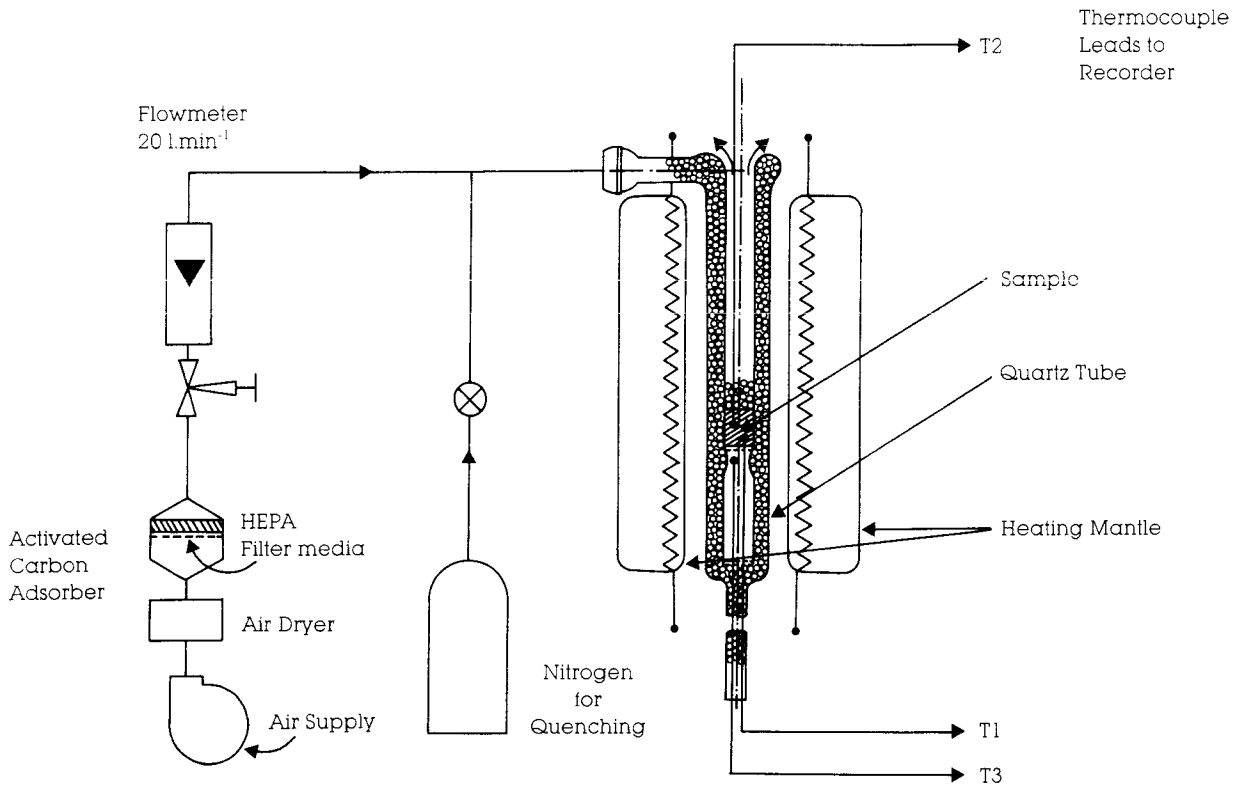

Ignition Apparatus Schematic

Reproduced with permission, from the *Annual Book of ASTM Standards*.  
 Copyright©, ASTM, 1916 Race Street, Philadelphia, PA. 19103.

Maintain the rate of heating of 2 to 3 °C.min<sup>-1</sup> until ignition is achieved, as indicated by a sudden rise in the temperature measured by the outlet thermocouple.

On ignition, cut off air flow immediately and introduce nitrogen to quench fire.

#### 3.4.6. **Result**

Obtain time-temperature plots of the temperatures measured by the thermocouples. Draw tangents to the heating curves before and after ignition. The ignition temperature is at the intersection of the tangents.

#### 3.4.7. **Note**

The ignition temperature as determined by this test cannot be interpreted as the probable ignition temperature of the same carbon under the operating conditions of a specific application, unless those conditions are essentially the same as those in this procedure.

#### Reference:

ANSI/ASTM D 3466 Ignition Temperature of Granular Activated Carbon.

Extracts were reprinted, with permission, from the *Annual Book of ASTM Standards*.

Copyright ©, ASTM, 1916 Race Street, Philadelphia, PA. 19103.

### 3.5. SELF IGNITION TEST ACCORDING TO IMDG-CODE

#### 3.5.1. Scope

Steam activated carbon is considered to be non-self-ignitable. Chemically activated carbon can be tested in this respect by means of the IMDG self-ignition test.

#### 3.5.2. Principle

The procedure of the International Maritime Dangerous Goods Code is used to determine whether a test carbon sample ignites at 140 °C under specified conditions.

#### 3.5.3. Apparatus

Oven:

A laboratory oven fitted with internal air circulation and capable of being controlled at  $140 \pm 2$  °C.

Wire mesh cube:

Construct an open top cube, 100 mm side, from phosphor bronze gauze 18.000 mesh per cm<sup>2</sup> (350 x 350 mesh). Place it inside a slightly larger, well fitting cube, made of phosphor bronze gauze 11 mesh per cm<sup>2</sup> (8 x 8 mesh). Fit the outer cube with a handle or hooks so that it can be suspended from above.

Temperature measurement:

A suitable system to measure and record the temperature of the oven and in the centre of the cube.

#### 3.5.4. Sample

1 litre of activated carbon as obtained.

#### 3.5.5. Procedure

Fill the cube with carbon and tap down gently, adding carbon until the cube is full. Suspend the sample in the centre of the oven, which has been preheated and regulated to  $140 \pm 2$  °C, for 12 hours and record the oven temperature and sample temperature.

#### 3.5.6. Result

Activated carbon fails the test if the temperature of the sample at any time during the 12 hours exceeds 400 °C.

Reference:

International Maritime Dangerous Goods Code (IMDG-CODE), class 4.2.

### 3.6. pH VALUE

#### 3.6.1. Scope

Activated carbon carrying inorganics and chemically active groups on its surface may alter the pH of liquids to which it is added.

A predictive standard test giving, a good approximation of actual conditions has been devised.

#### 3.6.2. Principle

According to the following procedure the carbon sample is extracted with boiling water. The pH of the extract obtained is defined as the pH value of the activated carbon.

#### 3.6.3. Apparatus and materials

pH-meter:

Readable in 0.1 pH units, with glass electrode and reference electrode, temperature range up to 80 °C. The reference electrode should be prevented from blockage by activated carbon particles.

Thermometer, 100 °C.

Hot-plate.

Distilled water.

Buffer solution pH 7.00.

Buffer solution pH 4.00.

#### 3.6.4. Sample

Use powdered carbon as received or grind granular carbon. Do not dry.

#### 3.6.5. Procedure

Weigh out 4.0 g of carbon into a 250 ml beaker, add 100 ml of distilled, CO<sub>2</sub> free (boiled out) water, cover with a watch glass and boil on the hot-plate for 5 minutes.

Insert the thermometer and set aside for a few moments to allow the bulk of the activated carbon particles to settle. Pour off the supernatant liquid as soon as possible and before it cools to 60 °C.

Cool the decanted portion to room temperature and measure the pH to one decimal place.

#### 3.6.6. Result

Record the result of the pH determination to one decimal place.

#### 3.6.7. Note

Sometimes the activated carbon settles too slowly. Addition of a few ml of neutral saturated NaCl solution may aid settling.

### 3.7. WATER SOLUBLE CONTENT

#### 3.7.1. Scope

The water soluble content gives an estimation of purity in relation to water extractable substances.

#### 3.7.2. Principle

A water extract is prepared and taken to dryness on a steam bath. The residue is dried to constant weight in an oven at 150 °C.

#### 3.7.3. Apparatus and materials

All glassware must be of a good quality borosilicate material.

Flasks, 250 ml, flatbottom, short neck with standard ground glass joint B 29.

Water cooled condenser, length 300 mm minimum.

Buechner funnel, glass «slit sieve» type, or porcelain, 75 mm disc diameter, with 500 ml receiver flask.

Hot-plate.

Volumetric flasks, 250 ml, glass stoppered.

Filter paper, ash free, high retention, of 70 mm diam.

Steam bath.

Oven, 150 ± 5 °C.

Evaporating dishes; glass, platinum or silica, 90 ml capacity.

#### 3.7.4. Sample

Granular activated carbon is pulverized (< 0.1 mm) and then dried at 150 °C to constant weight.

#### 3.7.5. Procedure

Weigh out 10.0 g of dry, powdered carbon into the flask, add 100 ml of water, mix the contents and connect the flask to the condenser. Bring to the boil on the hot-plate and reflux for one hour.

Just before the end of the hour period, prepare the filter as follows: wet the filter paper with water and position the disc on the funnel, applying gentle suction to obtain a proper leak-free filter.

Switch the hot-plate off, rinse the condenser with a little water, disconnect the flask and transfer the carbon slurry as hot as possible onto the filter in one go. Rinse the flask with three 25 ml portions of water and add the rinsings to the filter.

Drain the carbon cake fully by suction, cool the filtrate to ambient temperature and transfer it quantitatively to the 250 ml volumetric flask. Fill up to the mark and mix.

Weigh a dry and clean dish to the nearest 0.1 mg.

Pipet 50 ml of water extract into the dish and evaporate to dryness on a steam bath in a well ventilated fume cupboard.

Place the dish in the oven for 3 hours and reweigh after cooling in a desiccator for 15 minutes. Repeat the drying in the oven with one hour intervals until constant weight (0.2 mg).

### 3.7.6. **Result**

The water soluble content  $W_s$  in % is given by:

$$W_s = 100 \frac{B - G}{2}$$

where:

B = mass of dish plus water soluble in g

G = mass of empty dish in g

### 3.8. ACID SOLUBLE CONTENT

#### 3.8.1. Scope

The acid soluble content, like the ash content, gives a general indication of the purity of activated carbon.

#### 3.8.2. Principle

A hydrochloric acid extract is prepared and taken to dryness on a steam bath. The residue is dried to constant weight in an oven at 150 °C.

#### 3.8.3. Apparatus and materials

All glassware must be of a good quality borosilicate material.

Flasks, 250 ml, flatbottom, short neck with standard ground glass joint B 29.

Water cooled condenser, length 300 mm minimum.

Buechner funnel, glass «slit sieve» type or porcelain, 75 mm disc diameter, with 500-ml receiver flask.

Hot-plate.

Volumetric flasks, 250 ml, glass stoppered.

Concentrated hydrochloric acid, reagent grade (37%,  $d = 1,19$ ) (Merck art. nr. 317 or equivalent).

Filter paper, ash free, high retention, 70 mm diam.

Steam bath.

Oven,  $150 \pm 5$  °C.

Evaporating dishes; glass, platinum or silica, 90 ml capacity.

#### 3.8.4. Sample

The activated carbon is pulverized ( $< 0.1$  mm) and then dried at 150 °C to constant weight.

#### 3.8.5. Procedure

Weigh out 10.0 g of dry, powdered carbon into the flask, add 100 ml of water and mix the contents. Add 10 ml of concentrated hydrochloric acid and connect the flask to the condenser. Bring to the boil on the hot-plate and reflux for one hour.

Just before the end of the hour period, prepare the filter as follows: wet the filter paper with water and position the disc on the funnel, applying gentle suction to obtain a proper leak-free filter.

Switch the hot-plate off, rinse the condenser with a little water, disconnect flask and transfer the carbon slurry as hot as possible to the filter in one go. Rinse the flask with three 25 ml portions of water and add the rinsings to the filter.

Drain the carbon cake fully by suction, cool the filtrate to ambient temperature and transfer it quantitatively to the 250 ml volumetric flask. Fill up to the mark and mix.

Weigh a dry and clean dish to the nearest 0.1 mg.

Pipet 50 ml of hydrochloric acid extract into the dish and evaporate to dryness on a steam bath in a well ventilated fume cupboard. Place the dish in the oven for 3 hours and reweigh after cooling in a desiccator for 15 minutes. Repeat the drying in the oven with one hour intervals to constant weight (0.2 mg).

3.8.6. **Result**

The acid soluble content  $A_s$  in % is given by:

$$A_s = 100 \frac{B - G}{2}$$

where:

B = mass of dish plus acid soluble in g

G = mass of empty dish in g



### 3.9. TEST FOR POLYCYCLIC AROMATIC HYDROCARBONS

#### 3.9.1. Scope

The following procedure is used for the quick detection of extractable polycyclic aromatic hydrocarbon (PAH) compounds in activated carbon.

#### 3.9.2. Principle

A cyclohexane extract is prepared. Extracted PAH are detected by their ability to fluoresce strongly under ultraviolet light \*.

#### 3.9.3. Apparatus and materials

Soxhlet extractor.

UV source (365 nm).

Quinine.

Cyclohexane for spectrophotometry \*\*.

Sulphuric acid.

#### 3.9.4. Sample

Granular activated carbon is pulverized (< 0.1 mm) and then dried at 150 °C to constant weight.

#### 3.9.5. Procedure

Extract 10 g activated carbon sample in a Soxhlet extractor with 100 ml of cyclohexane, for 2 hours.

Collect the cyclohexane extract, adjust the volume to 100 ml and examine under ultraviolet light at 365 nm.

#### 3.9.6. Result

The fluorescence of the solution shall not be more intense than that of a solution containing 0.083 mg of quinine in 1000 ml of 0,01 N sulphuric acid.

#### 3.9.7. Notes

\* If an activated carbon contains other extractable fluorescent material, interference may occur.

More complicated separation methods should then be used. Descriptions are given in the recent literature, e.g. Borneff in «Activated Carbon Adsorption» Vol. I, p. 145/156 (1980), Ann Arbor Sci. (Michigan, USA).

\*\* Cyclohexane see European Pharmacopoeia Suppl. to Vol. III, p. 64.

Reference:  
European Pharmacopoeia.

### 3.10. HEAVY METALS CONTENT

#### 3.10.1. Scope

Limitations on the contents of some heavy metals are included in legislation for food, pharmaceuticals and similar products.

#### 3.10.2. Principle

Determination of the total amount of each heavy metal in the sample after total oxidation \* of the sample.

#### 3.10.3. Apparatus and materials

Wet ashing equipment.

Apparatus as required for individual metal analysis.

#### 3.10.4. Sample

Granular activated carbon is pulverized ( $< 0.1$  mm) but not dried. The moisture content should be known (see 3.2).

#### 3.10.5. Procedure

For the individual determination of each heavy metal use the best available method, e.g. atomic absorption \*\*.

#### 3.10.6. Result

The heavy metal content (ppm or wt.%) is calculated on a dry carbon basis.

#### 3.10.7. Notes

\* Dry ashing methods for oxidation should be avoided as some elements can volatilize during this process.

\*\* Contact activated carbon producers to select an appropriate method.

## NOMENCLATURE

|                        |   |
|------------------------|---|
| A                      | correction factor for iodine adsorption                                 |
| $A_c$                  | ash content   |
| $A_s$                  | acid soluble content  |
| $C_0$                  | initial concentration before carbon treatment                           |
| $C_t$                  | final, or residual, or equilibrium concentration after carbon treatment |
| $D_a$                  | absolute density  |
| $D_b$                  | bulk density  |
| $D_{Hg}$               | particle density  |
| $I_n$                  | iodine number   |
| K                      | constant of the Freundlich equation                                     |
| $K_1, K_2$             | factors of the modified Ergun equation                                  |
| L                      | carbon column length  |
| M                      | mass of activated carbon  |
| $M_r$                  | mass of a reference carbon  |
| $M_t$                  | mass of test carbon   |
| $M_c$                  | moisture content  |
| $1/n$                  | constant of the Freundlich equation                                     |
| $N_1, N_2, \dots, N_n$ | normality of solutions 1, 2, ..., n                                     |
| $N_r$                  | residual normality of iodine solution                                   |
| P                      | absolute pressure   |
| $P_B$                  | barometric pressure   |
| $Q_p$                  | phenol load of the carbon   |
| $Q_{pz}$               | phenazone load of the carbon  |
| RE                     | relative efficiency   |
| T                      | absolute temperature  |
| V                      | volume of...  |
| $V_d$                  | volatile matter content   |
| $V_o$                  | superficial velocity of gas   |
| $W_s$                  | water soluble content   |
| X                      | amount of material removed or adsorbed                                  |
| $\Delta P$             | pressure drop   |
| $\mu_T$                | dynamic gas viscosity, at T   |
| $\rho_{Hg}$            | density of mercury  |
| $\rho_{TP}$            | gas density, at T and P   |